

Swivel bracket SB000

Control the angle of your flat screen TV with this electric remote controlled swivel bracket. Simply adjust your TV-angle to make the TV face you wherever you sit in the room +/- 45 degrees.

SB000 possibilities:

- Combine with a small stand
- Mount inside a traditional fixed level TV cabinet
- Mount on the DF019 electric leg to raise and swivel above a sideboard cabinet
- Can also be used upside down e.g. for ceiling mounting

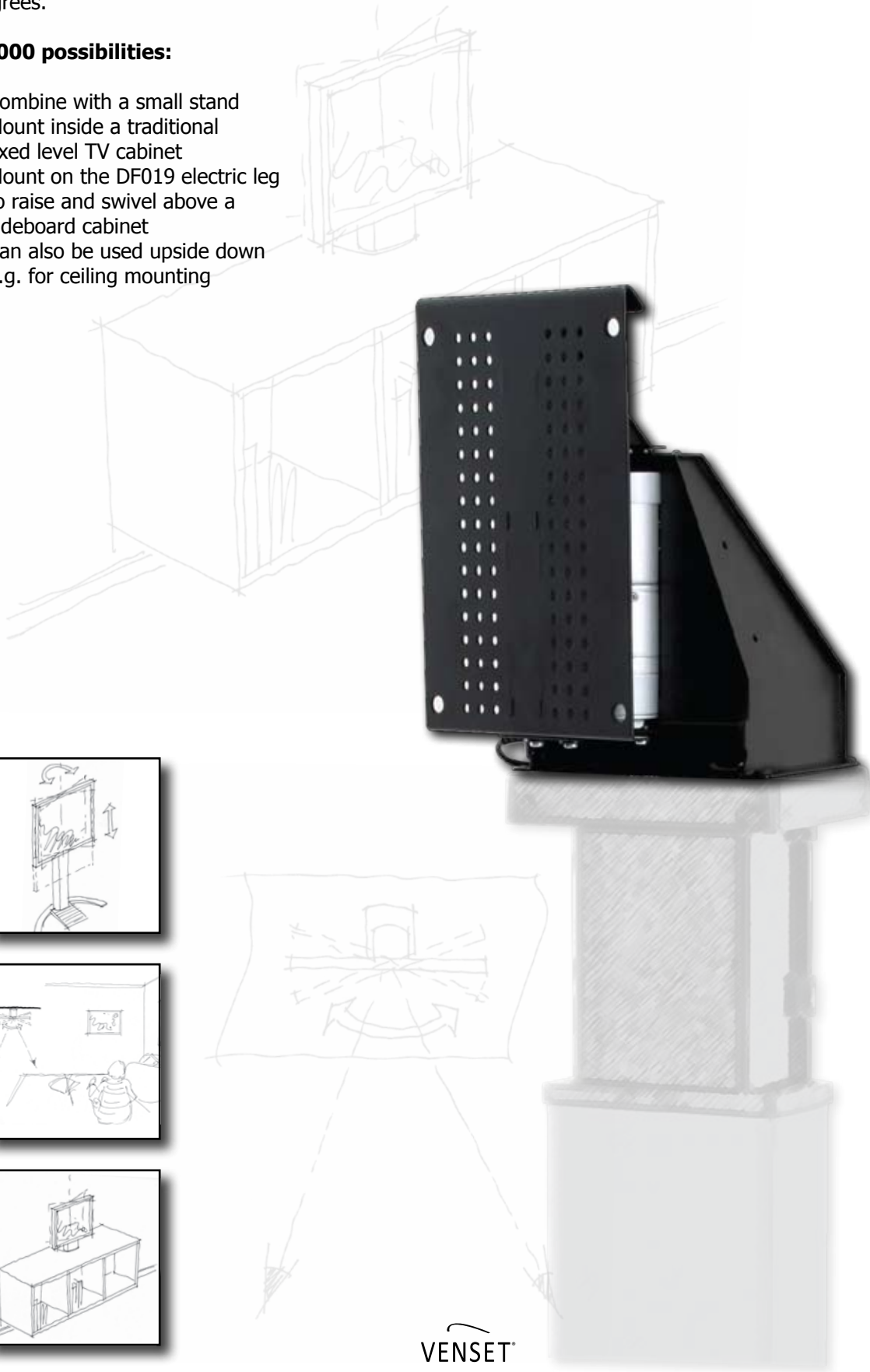

Swivel bracket SB000

Component specifications

Metal sheet parts:	St. 37-2
Gear parts:	St. 70-2
Gear motor:	FUI 24V 110040
Power supply:	90W AC SMPS Power Transformer
Consumption:	2 Watts; Standby: 0,01 Watts
Plastic components:	POM, PEHD, ABS
Surface treatment:	Visible metal parts powder coated in RAL 9004 (black) Non visible metal parts are surface treated (e.c. zinc plated)
Remote control:	Radio wave remote control (will also operate leg DF019 when used combined)
Angle of swivel:	+/- 45 degrees
Weight capacity:	50 kg

The unit is powder coated in RAL 9004 (black).

Fits Vesa std.:

- 50x50
- 75x75
- 100x100
- 100x200

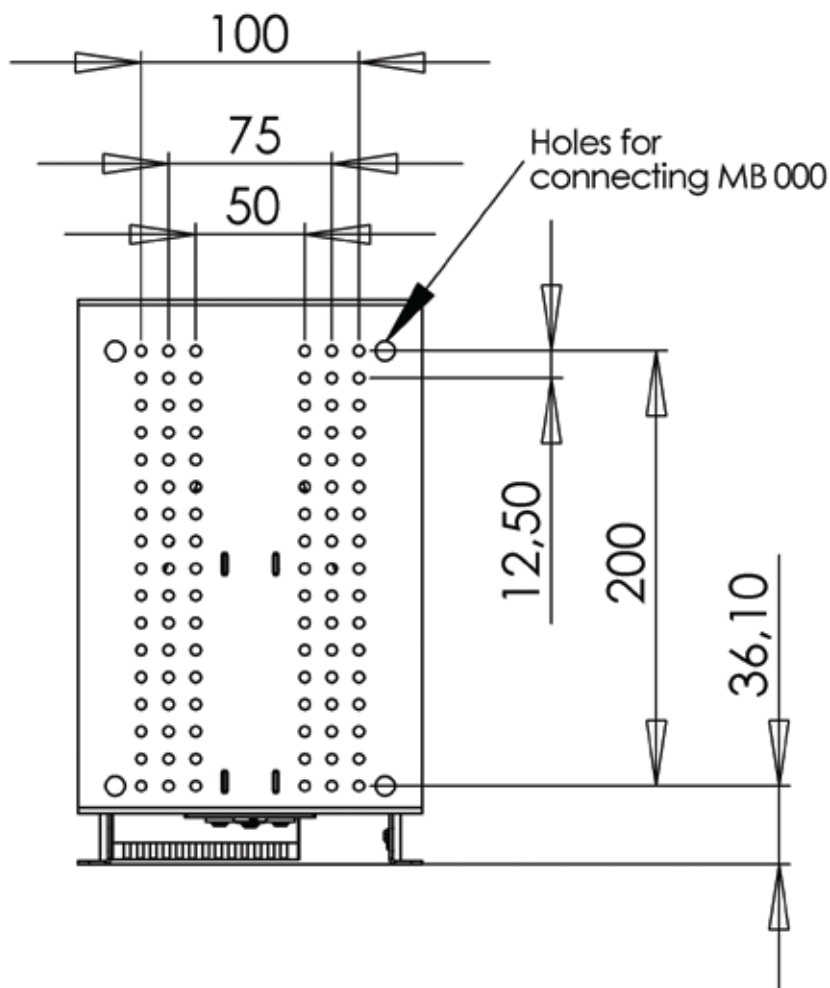

Swivel bracket SB000

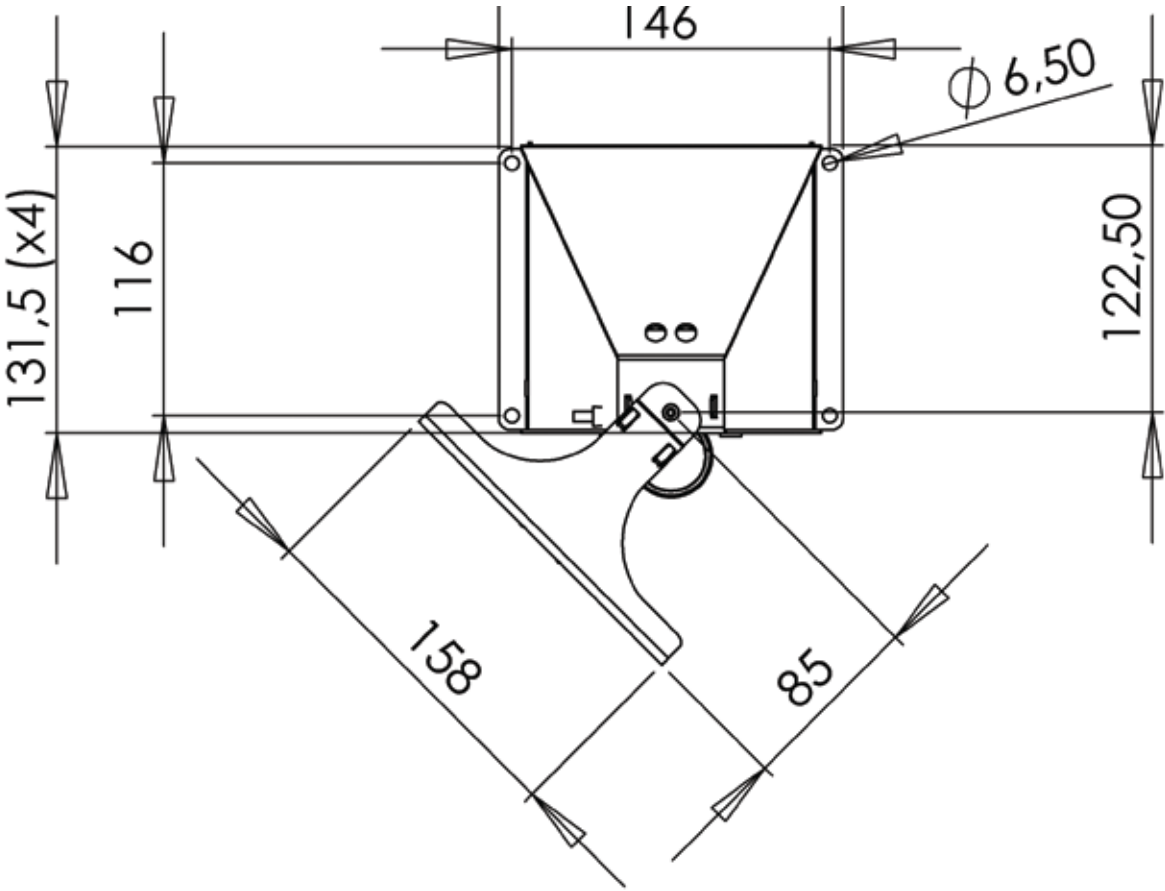
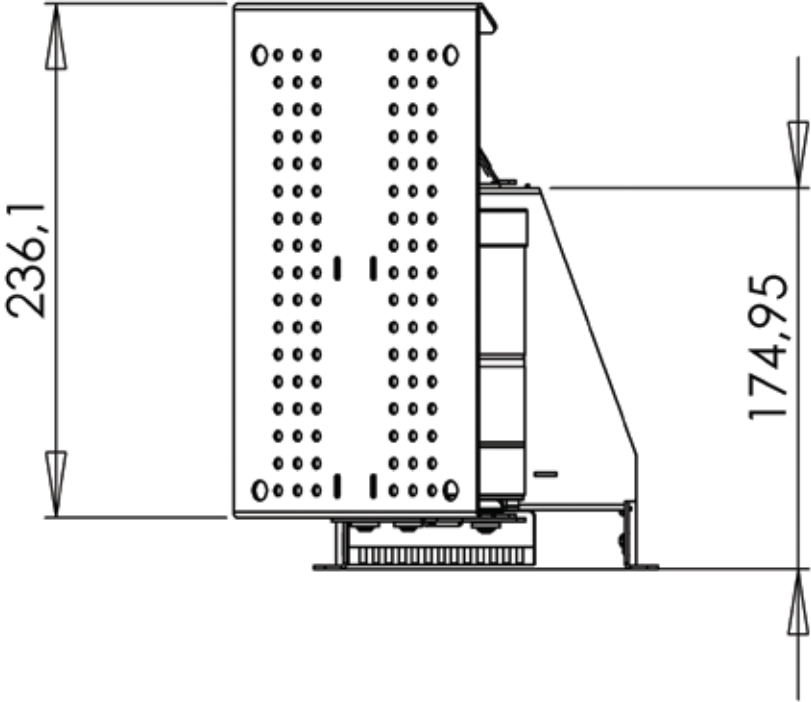

VENSET®

SB000 combination options

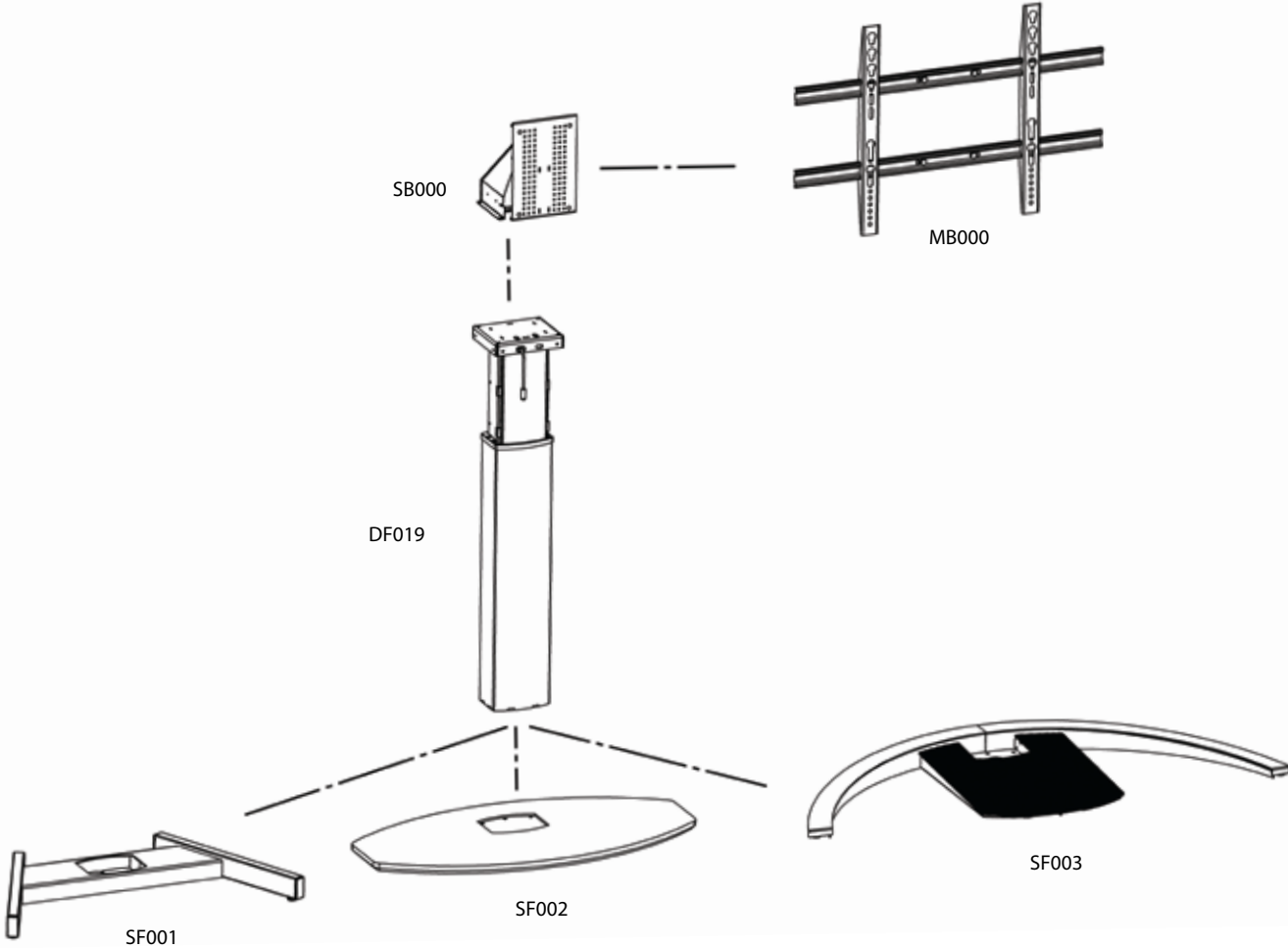
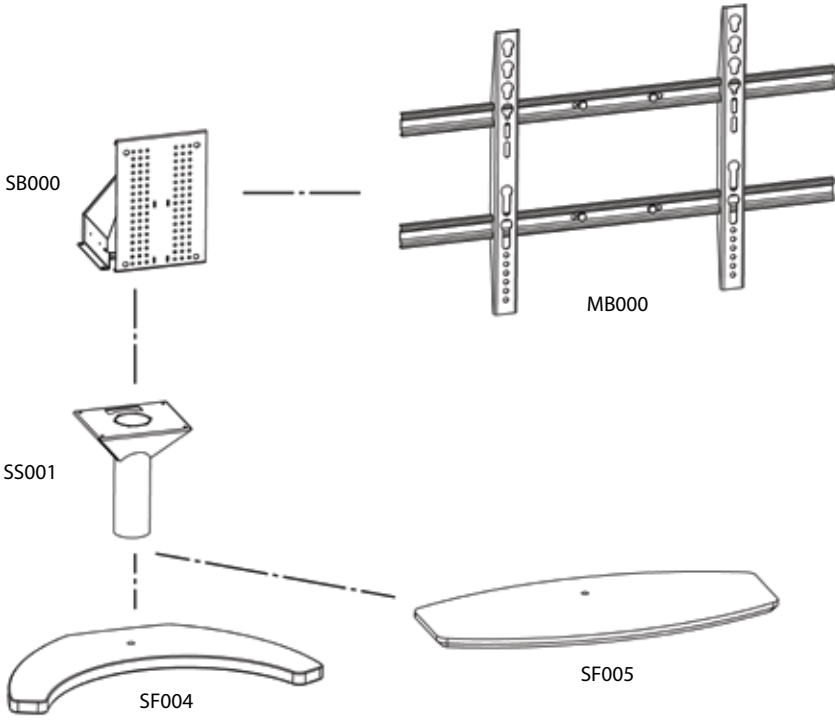

Inspiration for motorized TV stands

Electric swivel foot, black



A small swivel foot, which is ideal when placing the TV on a table, cupboard, bookcase etc.

Includes:

SB000 7BXX1 Electric swivel bracket, black
SS001 Swivel stand, black
SF004 XB Foot for swivel stand, black

Accessories:

MB000 B1: Monitor bracket, black

Electric swivel lift, black



An electric swivel lift with a superior design. Control both the height and angle of your flat panel TV with a remote control unit.

Includes:

SB000 7BXX1 Electric swivel bracket, black
DF019 7SXX1 Electric leg, silver
SF002 XB Foot for swivel lift, black

Accessories:

MB000 B1: Monitor bracket
MB001 B1: Monitor bracket, 800 mm

Electric swivel lift, Black



Includes:

SB000 7BXX1 Electric swivel bracket, black
DF019 7SXX1 Electric leg, silver
SF001 XB Foot for swivel lift, black

Accessories:

MB000 B1: Monitor bracket
MB001 B1: Monitor bracket, 800 mm
SF004 X4: 4 wheels



Accessory for SB000: DF019

This column is the solution for the furniture manufacturer, who wants to design and produce their own height adjustable systems. Extremely rigid construction in all load directions. Easy to adapt due to M6 treads at both ends.

The column is adjustable within the height range of 66-118cm. Powder coated in RAL9006. (Telescopic part comes in black)

Plug and play. Fitted with power supply (100-240 VAC) and control unit. Stand-alone product.



VENSET®

Accessory for SB000: MB000

Plasma/LCD mounting bracket.

Color: Black

Weight capacity: 100 kilos.

Fits Vesa std.:

200x200

400x100

400x400

600x200

600x400

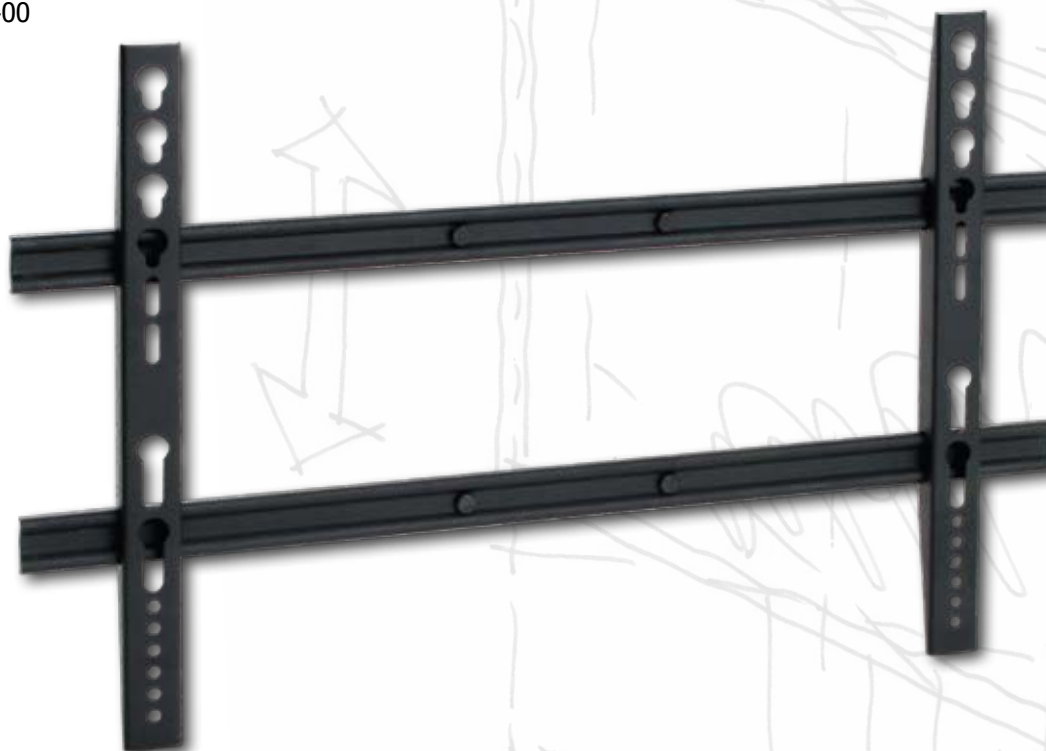

VENSET®